



A NEW AGE OF OUTDOOR LIVING
OUTDOOR FIRES & HEATERS





CONTENTS

ABOUT US	PAGE FOUR
LHOTSE 817	PAGE FIVE
LHOTSE 960	PAGE SIX
GONGGA	PAGE SEVEN
Q9	PAGE EIGHT
Q10	PAGE NINE
QOGIR 516	PAGE TEN
MUZTAG	PAGE ELEVEN
KONGUR 425	PAGE TWELVE
KONGUR 500	PAGE THIRTEEN
TECHNICAL	PAGE FOURTEEN



MUZTAG OUTDOOR FIRES LTD. ARE A NEW, INNOVATIVE COMPANY INTRODUCING A RANGE OF ORIGINAL, STYLISH OUTSIDE HEAT SOURCES.

Based in the South West of England, we specialise in the manufacture and distribution of outdoor gas fires.

Using over 30 years experience in the gas fire and stove industry, we offer a selection of aesthetically pleasing gas fire products with emphasis on functional and visual excellence.

We have various options available to cater for domestic and commercial customers. Our products are spectacular and a real show piece in any environment.

ALL OF OUR PRODUCTS ARE CE APPROVED, WITH SAFETY AS PARAMOUNT, AND HAVE BEEN DESIGNED, DEVELOPED AND MANUFACTURED IN ACCORDANCE WITH OUR TARGET MARKET.

We have new projects already underway and will continually invest into research and development.

Muztag Outdoor Fires Ltd will be visiting several exhibitions this year and would like to welcome distributors and consumers alike to join us.

We are extremely excited to have exclusive rights to this completely new range of products that we are sure will ignite people's imagination and prove to be a real success.



LHOTSE 817

If elegant appearance is the most important factor, then the Lhotse-817 is the obvious choice. With its striking black encasing and stylish glass facade this model will bring refinement to any setting.

- Concealed Cylinder
- 60cm Hose with 37mBar Propane Regulator
- LPG or Butane
- Variable Gas Valve
- Adjustable Feet
- Rain Cover
- Cylinder Slide Tray
- CE Approved



Burner Option
Stainless Star

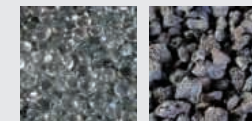

Fuel Options
Glass Bead Lava Rock



Surface Option **Body Option**
Black Glass Black Steel

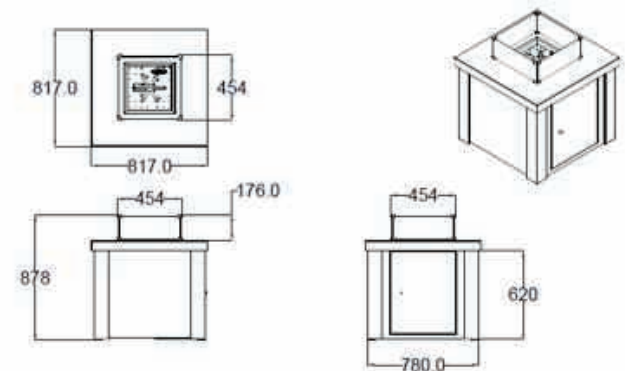

SPECIFICATIONS

Size	817 x 817 x 878mm
Weight	49kg
Input	7.3kw
Max Cylinder Size	496 x 256mm
LPG	37mBar
Butane	28-30mBar

LHOTSE 960

This freestanding table fire boasts uncomplicated but highly stylish design. Its clean, black steel finish will beautifully enhance any alfresco haven.

- Concealed Cylinder
- 60cm Hose with 37mBar Propane Regulator
- LPG or Butane
- Variable Gas Valve
- Valve Safety Key
- Adjustable Feet
- Rain Cover
- Cylinder Slide Tray
- CE Approved

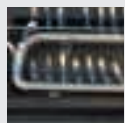

Burner Option
Stainless Straight

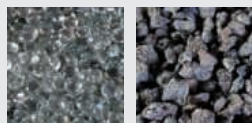

Fuel Options
Glass Bead Lava Rock



Surface Option **Body Option**
Black Glass Black Steel

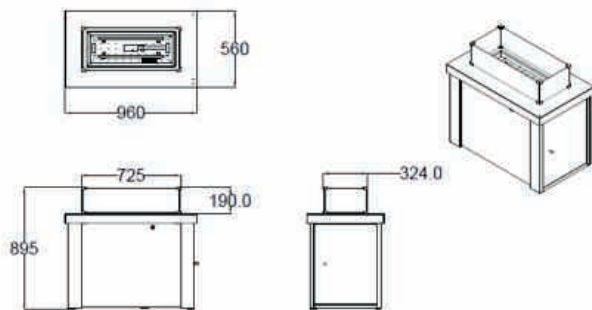

SPECIFICATIONS

Size	960 x 560 x 895mm
Weight	44kg
Input	14kw
Max Cylinder Size	318 x 580
LPG	37mBar
Butane	28-30mBar



GONGGA

The exquisite and ultramodern Gongga has both functionality and eye-catching design. The flame is mesmerizingly reflected in black mirrored glass, whilst the extensive surrounding ledge provides ample space for drinks or food.

- Concealed Cylinder
- 60cm Hose with 37mBar Propane Regulator
- LPG or Butane
- Variable Gas Valve
- Adjustable Feet
- Rain Cover
- CE Approved

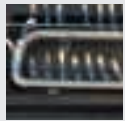

Burner Option
Stainless Straight

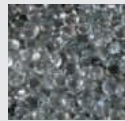

Fuel Options
Glass Bead Lava Rock



Surface Option
Black Glass

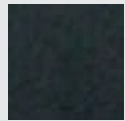

Body Option
Black Steel

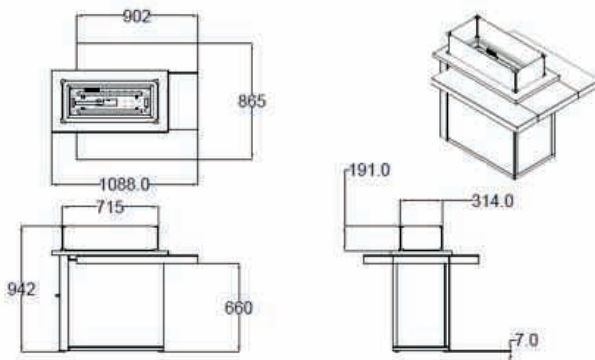

SPECIFICATIONS

Size	1088 x 865 x 942mm
Weight	58kg
Input	14kw
Max Cylinder Size	318 x 580
LPG	37mBar
Butane	28-30mBar







Q9

The Q9 will complement and transform any outdoor living environment. Its classic features and ceramic tile top give it an austere but distinguished style.

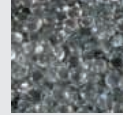
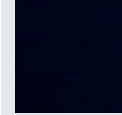
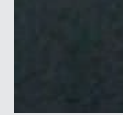
- Concealed Cylinder
- 60cm Hose with 37mBar Propane Regulator
- LPG or Butane
- Variable Gas Valve
- Adjustable Feet
- Rain Cover
- CE Approved

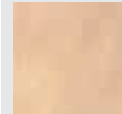
Burner Option	Fuel Options	Surface Options	Body Options
 Stainless Star	 Glass Bead	 Black Glass	 Black Steel
	 Lava Rock	 Ceramic Tile	

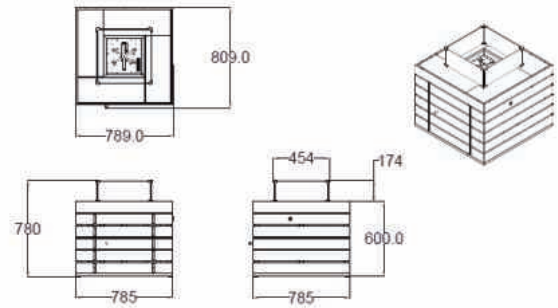

SPECIFICATIONS

Size	785 x 785 x 780mm
Weight	56kg
Input	7.3kw
Max Cylinder Size	496 x 256mm
LPG	37mBar
Butane	28-30mBar



Q10

This stylish table fire provides the ideal focal point for any exterior space. It's sleek black design and simple lines mean that it will perfectly complete any outdoor area, domestic or commercial.

- Concealed Cylinder
- 60cm Hose with 37mBar Propane Regulator
- LPG or Butane
- Variable Gas Valve
- Valve Safety Key
- Adjustable Feet
- Rain Cover
- CE Approved

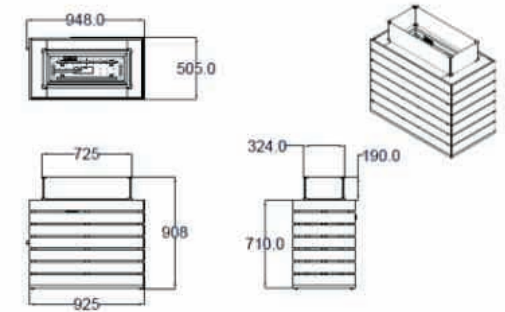
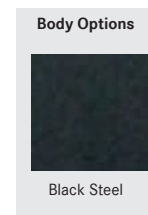
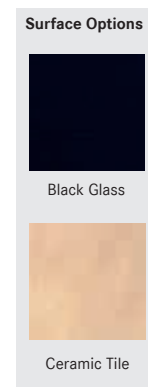
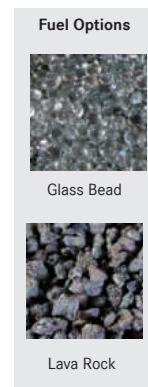
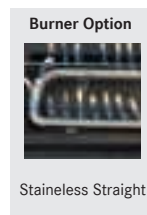

Size	948 x 505 x 908mm
Weight	50.5kg
Input	14kw
Max Cylinder Size	496 x 256mm
LPG	37mBar
Butane	28-30mBar

QOGIR-516

High/Low Base Open/Closed Top

The slender and sleek Qogir stands nobly with its inviting glass wings. The vibrant flames can be admired from 360 degrees, making it an ideal gathering spot at parties or functions.

- Concealed Cylinder
- 60cm Hose with 37mBar Propane Regulator
- LPG or Butane
- Variable Gas Valve
- Overturn Shutdown
- Valve Safety Key
- Adjustable Feet
- Rain Cover
- CE Approved
- Cylinder Slide Tray

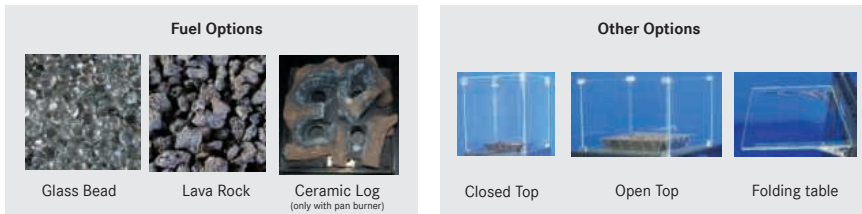
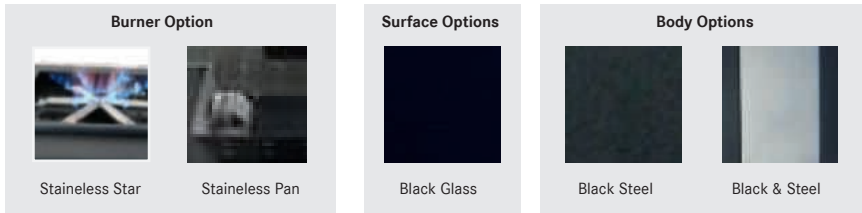

SPECIFICATIONS

High Base Closed Size	516 x 516 x 1718mm
High Base Opened Size	516 x 516 x 1513mm
Low Base Closed Size	516 x 516 x 1468mm
Low Base Opened Size	516 x 516 x 1263mm
High Base Closed Weight	48kg
High Base Opened Weight	42kg
Low Base Closed Weight	43kg
Low Base Opened Weight	37kg
Input	7.3kw
Max Cylinder Size	315 x 580mm
LPG	37mBar
Butane	28-30mBar

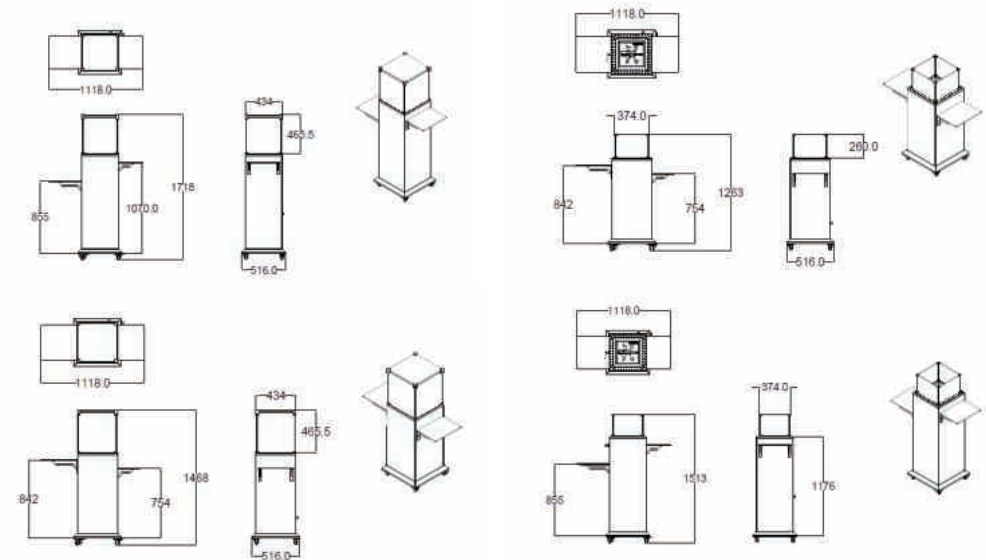

MUZTAG

Our signature fire will put a touch of grandeur into any surroundings. This multi seasonal heat source is perfectly suited to small areas ensuring balcony breakfasts are no longer a chilling experience.

- Concealed Cylinder
- 60cm Hose with 37mBar Propane Regulator
- LPG or Butane
- Variable Gas Valve
- Wheels
- Overturn shutdown
- Rain Cover
- CE Approved

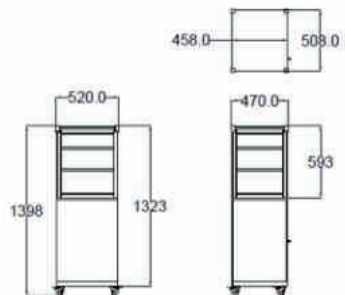
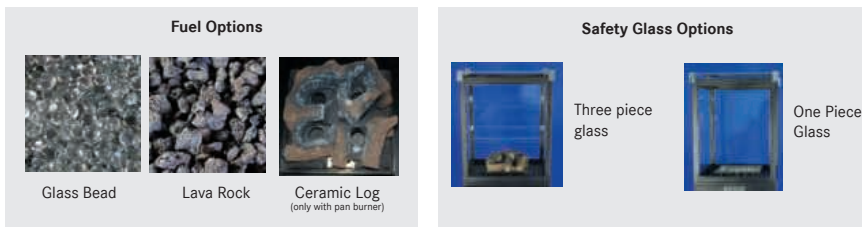
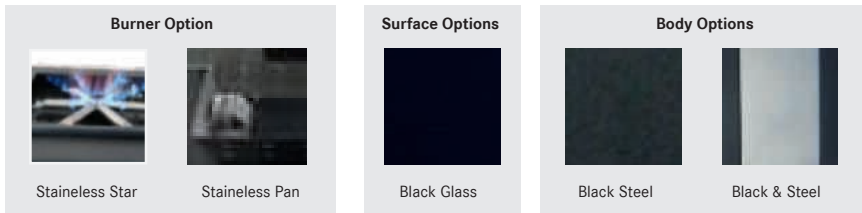

SPECIFICATIONS

Size	520 x 470 x 1398mm
Weight	45kg
Input	7.3kw
Max Cylinder Size	318 x 580mm
LPG	37mBar
Butane	28-30mBar





KONGUR 425

Bring a large space to life with the grandiose Kongur-425. Its 3D glass front houses a captivating flame against the black steel body. Ideal for larger gardens or venues, it can enhance a restaurant setting or bring the same al fresco dining experience to your own home.

- Concealed Cylinder
- 60cm Hose with 37mBar Propane Regulator
- LPG or Butane
- Variable Gas Valve
- Wheels
- Overturn shutdown
- Rain Cover
- CE Approved

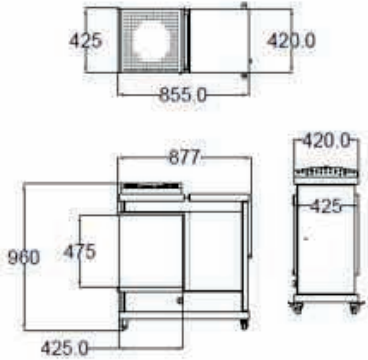
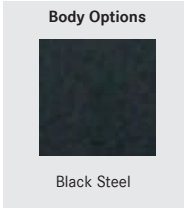
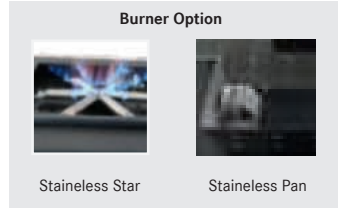

SPECIFICATIONS

Size	855 x 425 x 960mm
Weight	54.5kg
Input	7.3kw
Max Cylinder Size	318 x 580mm
LPG	37mBar
Butane	28-30mBar

KONGUR 500

The smaller sibling in the Kongur range is the Kongur-500, which boasts a stunning, powerful flame and elegant vertical design. Get more from your outdoor space all year round with this powerful and stylish fire.

- Concealed Cylinder
- 60cm Hose with 37mBar Propane Regulator
- LPG or Butane
- Variable Gas Valve
- Wheels
- Overturn shutdown
- Rain Cover
- CE Approved

Burner Option



Stainless Star



Stainless Pan

Body Options

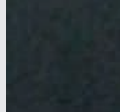

Black Steel

Fuel Options



Glass Bead



Lava Rock



Ceramic Log
(only with pan burner)

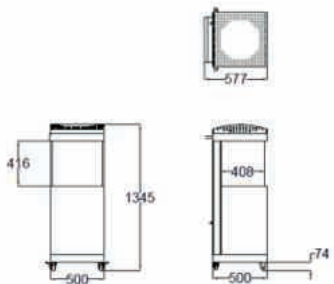

SPECIFICATIONS

Size	500 x 500 x 1345mm
Weight	48kg
Input	7.3kw
Max Cylinder Size	318 x 580mm
LPG	37mBar
Butane	28-30mBar





GAS & REGULATORS

All of our appliances can be used with bottled Propane or Butane. We provide, as standard, a 27mm Clip-On Regulator suitable for Propane to 37mBar pressure. This is suitable for most domestic Propane gas cylinders available at garden centres, retailers and gas suppliers.

All products are CE Approved for full compliance.

WARRANTY & SPARE PARTS

Our products come with 12 month manufacturers' warranty. However, if something gets lost or broken or needs a replacement there are spare parts available to buy. These are detailed in the instruction manuals and can be found on our website.





PO BOX 318,
TORQUAY,
TQ1 9HR

TEL: +(0)1803 428260
EMAIL: SALES@MUZTAGOUTDOORFIRES.CO.UK
VISIT: WWW.MUZTAGOUTDOORFIRES.CO.UK