

Gas Fire Patio Heater Qogir-516



Instruction Manual

Please read the manual **BEFORE** you unpack or install the fire

TABLE OF CONTENTS

Warning	3
Getting Started	4
What's Included	5
Assembly Procedures	6
Product Drawing	8
Heater Stand and Location	10
Gas Requirements	10
Leakage Test	11
Lighting Instructions	11
After Use and Storage	12
Cleaning and Maintenance	12
Troubleshooting Checklist	13
Spare Parts	14
Warranty	15
Contact	16

WARNING

**PLEASE READ CAREFULLY THE FOLLOWING SAFETY GUIDELINES BEFORE OPERATION AND INSTALLATION
REPAIRS SHOULD ONLY BE DONE BY A QUALIFIED TECHNICIAN**

- Do not use this appliance for indoors, as it may cause personal injury or property damage. **THIS APPLIANCE MUST ONLY BE USED OUTDOORS.**
- Do not connect the heater to any gas supply until it has been fully assembled.
- This outdoor heater is not intended to be installed on recreational vehicles and/or boats.
- Appliance should be located on a solid surface.
- Maintenance and repair should be carried out by a qualified technician.
- Improper installation, adjustment, alteration can cause personal injury or property damage.
- Do not attempt to alter the unit in any manner. Any modifications may be dangerous and are not permitted.
- Do not store or use petroleum or other flammable vapors or liquids in or near the heater unit.
- The whole gas system, hose, regulator, pilot or burner should be inspected for leaks or damage before use, and at least annually by a qualified technician.
- All leak tests should be done with a soap solution. Never use an open flame to check for leaks.
- Do not use the heater until all connections have been leak tested.
- Turn off the gas valve if smell of gas is detected and immediately shut off any gas supply.
- Do not move heater while it is operation.
- Do not move the heater until temperature has fully cooled after it has been turned off.
- Control compartment, burner and circulation air passageways of the heater must be kept clean.
- Frequent cleaning may be required as necessary.
- All gas cylinders should be turned off when the heater is not in use.
- Check the heater immediately if any of the following occurs:
 - The heater does not reach temperature.
 - The burner makes popping noises during use (a slight noise is normal when the burner is extinguished).
 - Smell of gas in conjunction with extreme yellow tipping of the burner flames.
 - The burner does not ignite or continues to go out
- The gas regulator and hose assembly must be located in the cylinder cabinet where gas cylinder is installed.
- Any guard or other protective device removed for servicing the heater must be replaced before further use.
- Adults and children should stay away from high temperature surfaces to avoid personal injury or property damage. **WARNING: Accessible parts may be very hot.**
- Children should be carefully supervised at all time when they are in the area of the heater.
- Clothing or other flammable materials should not be hung on the heater or placed on or near the heater.
- Do not use the heater for any form of cooking.
- Do not throw anything into the heater.
- Do not leave the heater unattended whilst in operation.
- Do not use heater in excessively windy conditions.
- Do not use heater in excessively rainy conditions, as this could lead to damage to components.
- Ensure the gas supply is isolate and shut off when not in use and gas control valve is in the OFF position.
- Follow all instructions regarding the use of LPG and Butane bottles. Please contact your local gas supplier for further advice if needed.
- **WARNING: Flames from the heater are almost invisible in direct sunlight.**

GETTING STARTED

Please read instruction thoroughly before using the appliance.

The gas heater will arrive in one box containing the appliance with burner already installed, adjustable feet, surrounding safety glass with brackets, valve ignition key, standard propane regulator, 60cm gas hose, glass and lava rock fuel beds and rain cover. Also included could be ceramic log set if tray burner and log option were ordered.

Remove the appliance from packaging. Carefully place it down on the floor, keeping it upright for ease of assembly.

Extreme care should be taken when handling the heater, to ensure the gas pipes, thermocouple lead, gas valve or burner are not damaged or loosened in anyway.

Please note: ALL heaters have been burn tested and leak tested prior to leaving the factory. Although each unit is cleaned, there may be the odd scorch mark around the pilot and main burner gas jets.

Specification

The gas heater is designed to work with the following gas types.

Gas Type	LPG - G31 Propane	LPG - G30 Butane
Appliance Category	I 3+	I 3+
Supply Pressure	37 mbar	28-30 mbar
Heat Input	Max. 7.3KW	Max. 7.3KW
Maximum Flow Rate	521g/hr	531kg/hr

Gas Bottle & Regulator

The appliance includes 27mm clip-on regulator with 8mm inlet and 60cm of gas hose. This has a flow rate capacity of 1.5kg/hr and operates a supply pressure of 37mBar. It is suitable for most domestic propane gas cylinders available at garden centres, retailers and gas suppliers.

Other regulators are available depending on the gas type and cylinder size. Please ensure that a suitable regulator with a minimum flow rate capacity of 1.3kg/hr and relevant supply pressure is used. Please contact your local gas supplier for further advice if needed.

The gas hose should be checked regularly to ensure it is in good condition and it is recommended that it is replaced in accordance with standard practices.

Propane or Butane

Although the heater will work with either propane or butane, there is a difference between the two gasses. Butane cannot be used in temperatures below 5°C, whereas propane can be used all year round. We would recommend propane.

WHAT'S INCLUDED

Appliance Heater including Gas Cylinder Slide Tray		
Adjustable Feet		
Surrounding Safety Glass and Brackets	<p>Opened Top</p> 	<p>Closed Top</p> 
Standard Propane Regulator & 60cm Gas Hose		
Glass and Lava Rock Fuel Beds		
Rain Cover		
Gas Valve Safety Ignition Key		
<p>OPTION FOR TRAY BURNER ONLY Ceramic Log Set (if ordered)</p>		

ASSEMBLY PROCEDURES

Remove the heater body and all of the parts from carton, then follow below procedures.

STEP 1 – Adding Fuel Bed

Option 1 - Glass or Lava Rock for Star or Pan Burner

This should be done outside.

Cover the burner with either glass or lava rock fuel beds. DO NOT tip the bag of glass or lava rock onto the burner as the bags usually contain some fine dust which could clog the burner jets. It is better to empty the bags into a suitable container and then place the glass or rock by hand around the burner. Make sure the area around the pilot light is kept clear to allow air to reach.

Positioning of Glass or Lava Rock on the Burner – Keep Pilot Area Clear



Option 2 – Log for Pan Burner Only

This ceramic log set is a molded one piece set.

Carefully lay this flat over the pan burner ensuring the holes in the ceramic line up with the hole on the burner.



STEP 2 – Installing Surrounding Safety Glass

Option 1 – Opened Top Appliance

Using a HEX Key fix the surrounding safety glass together with the supplied glass brackets and screws. This will need to be done with two people. Place the safety glass around the burner area.



Option 2 – Closed Top Appliance

Using a HEX Key fix the surrounding safety glass together with the supplied glass brackets and screws around the sides of the burner. Then using a HEX Key fix the top safety glass to the top of appliance with the supplied glass brackets and screws. This will need to be done with two people.



The Gas Hose

The appliance is supplied with 27mm clip-on regulator with 8mm inlet already attached which is suitable for propane.

If you want to use a different regulator type or gas type then you will need to remove the installed regulator and replace to your requirement. To change the regulator ensure to attach the gas hose to the gas inlet connector and secure with the hose clip. New hoses can be quite stiff and hard to push onto the inlet pipe, so soften the end of the hose by running it under a hot tap for a few seconds. Try not to get water inside the hose.

PRODUCT DRAWING

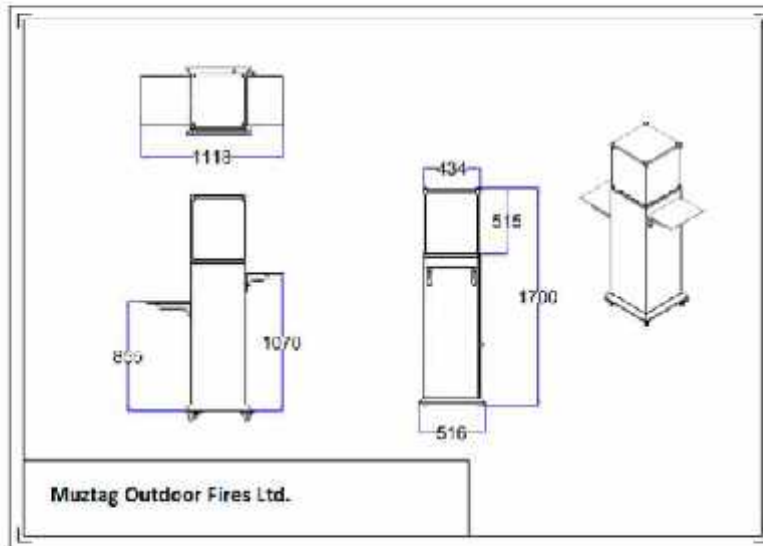

High Base Closed Top

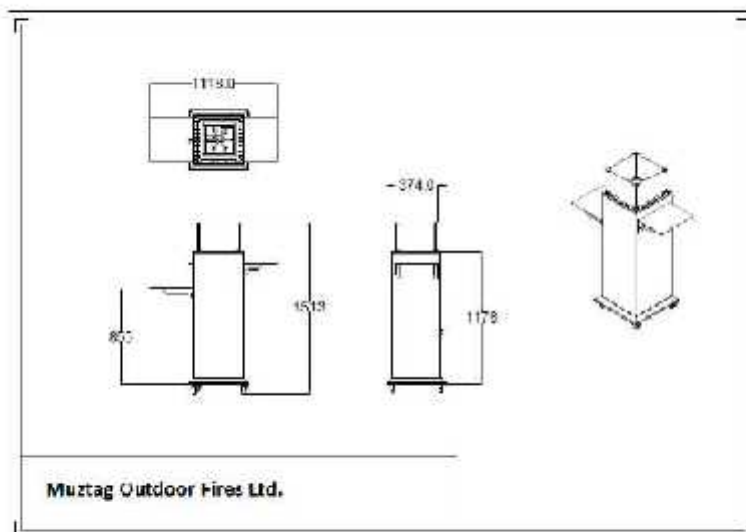

High Base Opened Top

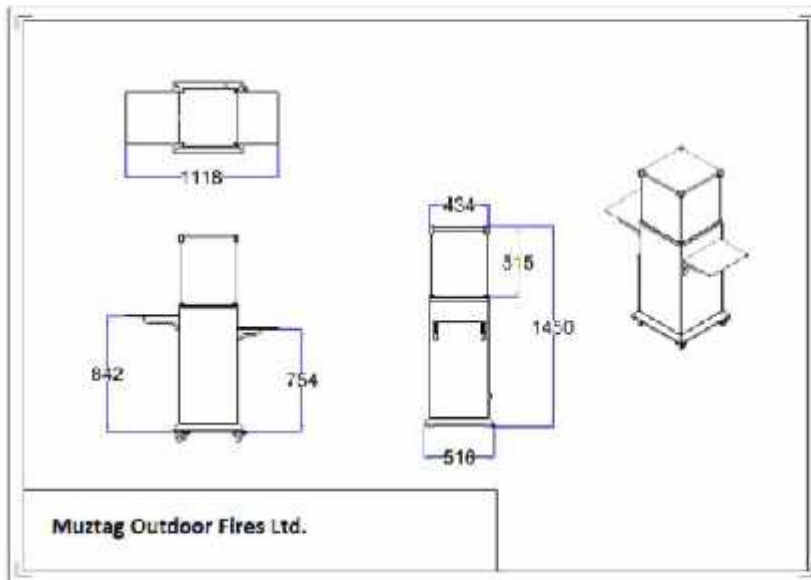

Low Base Closed Top

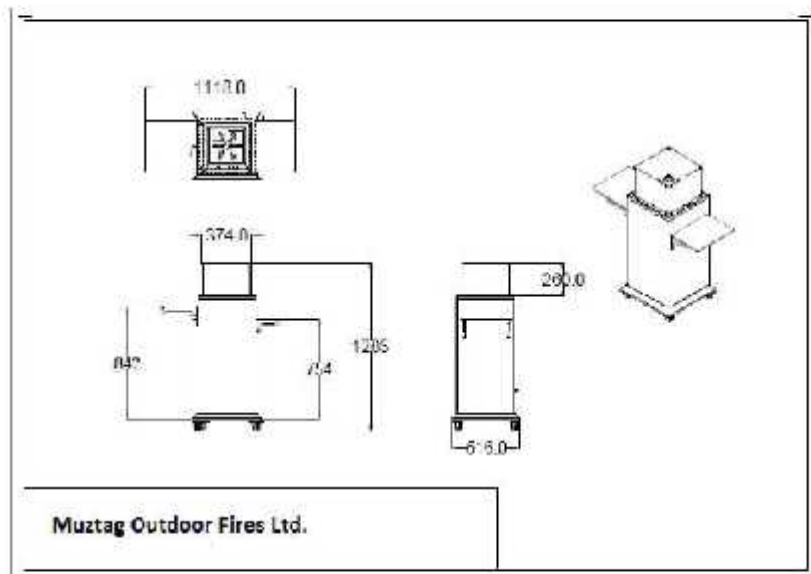

Low Base Opened Top

HEATER STAND AND LOCATION

- The heater is for outdoor use only. Always ensure that adequate ventilation is provided.
- Always maintain proper clearance to combustible materials of at least 2 metres.
 - Do not place near to your house.
 - Do not place near to shed, garage or fences.
 - Do not place under roof covering or low overhanging trees
 - Do not place near to power sources or under overhanging power cables.
- Heater must be placed on level firm ground. Ensure that castor wheels are locked into place.
 - The appliance is fitted 'Overturn Shut Off Device'. If the appliance is tilted or does not stand vertically or was to fall over it will automatically shut off gas supply and appliance would shut down.
- Never operate heater in an explosive atmosphere where petroleum or other flammable liquids and gases are stored.

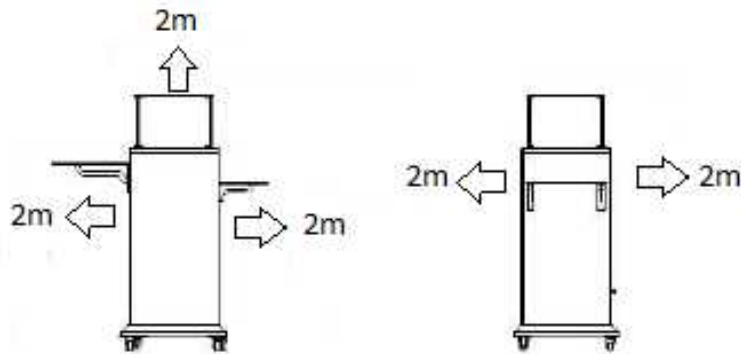

The Gas Hose

It's extremely important that you DO NOT route the gas hose under the directly under burner. Do not allow the hose to touch any part of the burner or heater. The hose should be located so that it is not subjected to undue strain or placed where it could be damaged.

GAS REQUIREMENTS

- Use propane or butane gas only.
- Always use the correct pressure regulator and hose assembly suitable for the gas cylinder. Contact your local gas supplier for further advice if needed.
- Dented, rusted or damaged gas cylinders may be hazardous and should be checked by your gas supplier.
- Never use a cylinder with a damaged valve connection.
- Never connect an unregulated gas cylinder to the heater.

Maximum Gas Bottle Size

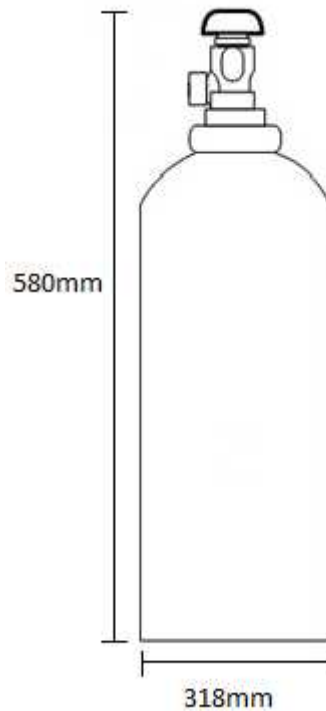

LEAKAGE TEST

Gas connections on the heater are leak tested at the factory prior to shipment. A complete leakage test should be performed at the installation due to possible mishandling in shipment or excessive pressure being applied to the heater.

- Make a soap solution of one part liquid detergent and one part water. The soap solution can be applied with a spray bottle, brush or rag. Soap bubbles will appear in case of a leak.
- The heater must be checked with a full cylinder.
- Make sure the safety control valve is in the 'OFF' position.
- Turn the gas supply from the cylinder ON.
- In case of a leak, turn off the gas supply. Tighten any leaking fittings, then turn the gas supply on and recheck.
- Never do leak test while smoking.

LIGHTING INSTRUCTIONS

- Open the cabinet door and put the gas cylinder into the cabinet using the cylinder slide tray.
- Make sure to turn the control knob clockwise to "OFF" position.
- Connect the regulator to the gas bottle.
- Turn the gas supply "ON" at the cylinder. Check with the use of soapy water for any gas leakage between the cylinder and the regulator
- Push down the control knob and keep pressing whilst turning anti-clockwise to the "Ignition" position (a click will be heard), this will light the pilot.

- If the click is not heard repeat this process. Note that when first connecting heater to the gas cylinder there will be air in the gas hose or the rest of the system. Keep pressing the control valve knob for about 1 minute to purge the air and allow gas into system.
- Once the pilot burner is lit, keep the control knob pressed for 5 seconds then release it.
- If the burner does not stay alight, repeat the above steps again.
- Adjust the heat setting by turning the control knob to the 'High' or 'Low' position.
- To shut down the heater turn the gas cylinder valve or regulator switch to the 'OFF' position and then turn the control valve knob on the appliance clockwise to the 'OFF' position.

WARNING:

If the burner fails to ignite, turn the control valve knob 'OFF' (clockwise) and turn the gas cylinder valve 'OFF'. Wait for five minutes before attempting to relight with ignition sequence.

AFTER USE & STORAGE

- Turn the control knob on the appliance clockwise to the 'OFF' position.
- Turn the gas supply off at the cylinder.
- Do not leave the area until flames have fully extinguished.
- Children must not be left unattended straight after use as the appliance will still be hot for some time.
- Check gas valve for tightness and damage. If damage is suspected this must be changed by a qualified technician.
- Always store gas cylinders in well ventilated areas.
- Once heater has cooled down it can be moved to alternative location such as garage or shed.
- Once heater has cooled down it is safe to use rain cover for protection.

CLEANING & MAINTENANCE

- Ensure all cleaning is done whilst heater is turned off and fully cooled down.
- Wipe surfaces with a soft, damp cloth.
- Do not use any corrosive or combustible cleaning solutions.
- Keep the outdoor fire covered when not in use to stop rain from blocking the burner jets.
- Make sure burner is kept clean and clear of combustible materials and dirt.
- Soot can build up on the glass beads, lava rocks and ceramics logs. This could block burner jets so remove the fuel bed and wipe with damp cloth to clean soot.
- Soot can build up on the surrounding safety glass. Carefully remove the glass from glass bracket with relative screwdriver, wipe soot with a soft, damp cloth, then carefully replace. Two people maybe required disassembly and reassembly of the surrounding safety glass.
- Ensure the condition of gas hose is suitable and shows no signs of cracking or general wear & tear.
- It is advised to get the appliance check by a qualified technician every 3 years.
- If the burner jets do get blocked by soot or other dirt then remove the fuel bed and use a pin or paperclip. Ensure the burner is switched
- Follow the above maintenance steps on a regular basis.

TROUBLESHOOTING CHECKLIST

Pilot will not light or stay on

- Ensure gas supply is turned on and cylinder is not empty.
- Press ignition button several times. Ensure to keep the main gas lever pressed in for at least 10 seconds.
- If the ignition button stays stuck in then lubricate with WD40 whilst the heater is not lit.
- Keep trying as air can get trapped in pipes and can take some time to purge all the air out of the system.
- Check that glass or lava rocks or other debris are not covering the pilot.
- Check to see if any connections are loose and tighten if required.
- Check to see if there is a leak in the gas hose. Replace if required.
- Try lighting the pilot with a match or lighter if the spark electrode is wet or damaged.
- Ensure that the appliance is on level ground and completely vertical as the 'Overturn Shut Off Device' may have been triggered.

Burner will not light

When the pilot is lit, there should be no reason the main burner would not light.

- If the pilot is lit but the burner does not light check if too much glass or lava rock is around pilot assembly. This could block the pilot light from igniting the main burner.
- If the pilot is lit but the burner does not light there could be damage to the control valve. This would need replacing by a qualified technician.
- If the pilot is not lit the flame failure device has cut off the gas supply. Wait 3 minutes, then try relighting the pilot.
- Ensure that the appliance is on level ground and completely vertical as the 'Overturn Shut Off Device' may have been triggered.

Main Burner suddenly goes out.

- If the pilot is extinguished for any reason (sudden gust of wind or it started raining) then the main gas supply would automatically cut off.
- Turn the control lever to the 'OFF' position, and leave for 3 minutes before relighting the pilot.
- Once the pilot is lit the main burner will work.
- The gas cylinder may be empty. If so, replace the cylinder with a full one.
- Ensure that the appliance is on level ground and completely vertical as the 'Overturn Shut Off Device' may have been triggered.

SPARE PARTS

GFOSP005	Gas Control Valve & Oxypilot Kit
GFOSP004	Propane 27mm Clip-On Regulator 37mBar
GFOSP003	60mm Gas Hose
GFOSP002	Gas Valve Safety Ignition Key
GFOSP001	Adjustable Feet
GFOSPGFB3.7	Glass Fuel Bed 3.7kg
GFOSPLFB2.0	Lava Rock Fuel Bed 2.0kg

Option 1 – For Opened Top Appliance

GFOSPSG348*250	Surrounding Safety Glass 348*250*5mm
-----------------------	---

Option 2 – For Closed Top Appliance

GFOSPSG428*404	Surrounding Safety Glass 428*404*5mm
GFOSPSG420*420	Surrounding Safety Glass 420*420*5mm

Option 3 – For Tray Burner Only

GFOSPLFB1.45	Ceramic Log Fuel Bed 1.45kg
GFOSPGFB2.1	Glass Fuel Bed 2.1kg
GFOSPLFB1.0	Lava Rock Fuel Bed 1.0kg

Option 4 – For Appliances with Side Tables

GFOSPSGQST	Safety Glass Qogir-516 Side Table
-------------------	--

Option 5 – For Rain Covers

GFOSPRC005	Qogir-516 High Base Closed Rain Cover	High Base Closed Top Appliance
GFOSPRC006	Qogir-516 High Base Opened Rain Cover	High Base Opened Top Appliance
GFOSPRC007	Qogir-516 Low Base Closed Rain Cover	Low Base Closed Top Appliance
GFOSPRC008	Qogir-516 Low Base Opened Rain Cover	Low Base Opened Top Appliance

MUZTAG OUTDOOR FIRES WARRANTY

All Muztag Fires Ltd. gas fire appliances are covered by a 12 month limited warranty. Should there be any problems, please contact the retailer or supplier from where the appliance was purchased. Please quote serial number, which can be found on the label on the back side of door.

1. The warranty protects the appliance for the end user against defects in materials and workmanship for the period of one year, which begins on the date of purchase by the customer.
2. Under the warranty the end user is responsible for the cost of packaging and shipping the unit to Muztag. Muztag are not liable if the appliance is improperly packed resulting in damage during transit. Please retain all original packaging together with manuals, as this will assist in returning the product in the correct packaging.
3. Muztag will rectify the fault within a reasonable amount of time from the point of receipt at our factory.
4. The warranty covers only those defects which arise as a result of normal use of product, and do not apply to any: a) Improper and inadequate maintenance or modification; b) Repairs carried out by non-qualified technician; c) Damage caused by improper handling or installation; d) Operation outside the product specifications; e) Physical damage, accidental damage, neglect, or user abuse; f) Normal wear and tear.
5. If there is no fault found or the problem has been caused by third party, user error or physical damage and any of the reasons stated in section 4, a 'no fault found' charge and then any subsequent transport costs will be applied. Confirmation this charge will be given within 14 days of the item being tested.
6. The warranty applies to the original owner of the appliance and is non transferable.
7. Muztag reserve the right to repair or replace any faulty components. Faulty goods may be replaced with factory-refurbished products.
8. The warranty is void if, there is any attempt made to repair the system by a non-qualified third party, or if the system is inadequately or improperly maintained or modified All repairs and replacements will carry a 90 days warranty or the original warranty balance, whichever is greater.
9. Muztag reserve the right to replace discontinued products that are still under warranty with the nearest equivalent specification product.
10. This document is not proof of purchase or proof of warranty. Retain your proof of purchase.
11. Total liability extends only to the purchase price paid for the appliance, except where such a limitation is prohibited by statute.
12. Muztag, in the event of a warranty claim, reserves the right to either replace the appliance in question or to refund the purchase price of the appliance.

Goods Damaged in Transit

If goods are visibly damaged on receipt, it's important to sign for the goods as damaged on arrival with the courier and then contact the retailer or supplier immediately.

CONTACT



Muztag Fires Ltd. T/A Muztag Outdoor Fires

Address: PO Box 318, Torquay, TQ1 9HR

Tel: +(0)1803 428260

Email: sales@muztagoutdoorfires.co.uk

www.muztagoutdoorfires.co.uk

Serial Number:	S/N _____
Pin Number:	0063CS7870